

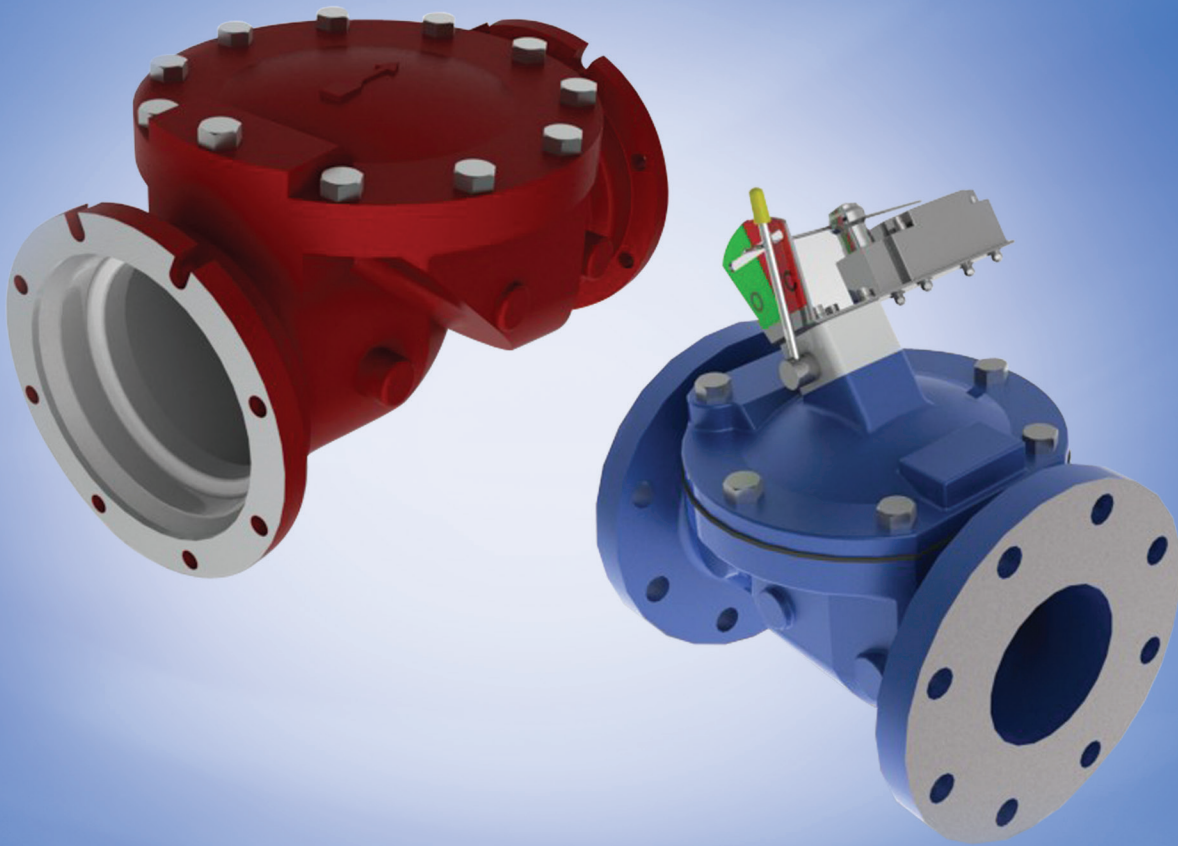

ISO 9001 CERTIFIED

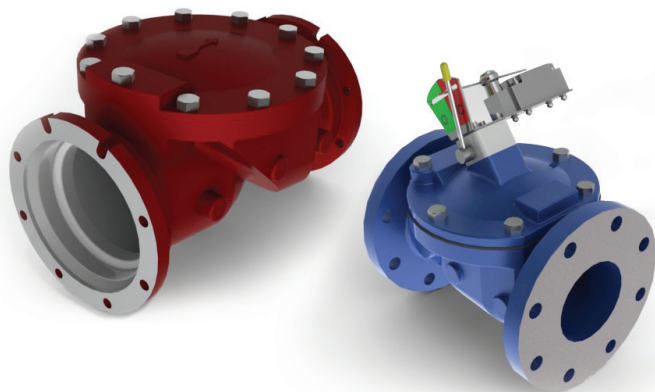

**FLEX CHECK  
FLEXIBLE DISC CHECK VALVES**



### Construction Specifications:

- Sizes:** 2" through 24" flanged ends  
3" through 16" mechanical joint ends
- Body:** Ductile Iron
- Disc:** Buna-N encapsulated steel
- Seat:** 45° non-slam seat

**NOTE:** Shown with optional disc position indicator and limit switch

The Milliken Series™ 851 Flex Check Valve has only one moving part: a resilient disc reinforced with steel. This simple, innovative valve provides dependable, maintenance free performance, and quiet operation with its inherent non-slam construction. The large, unobstructed flow path makes the valve an excellent choice for wastewater as well as water applications. The design has undergone a rigorous 1,000,000 continuous cycle test with no signs of wear or distortion to the valve disc or seat. All sizes have a 250 psi rating.

## FEATURES

### Body

Ductile Iron in ASTM A-536 Grade 65-45-12, and features a full flow area providing 100% unrestricted flow and low head loss. Flanges are in full compliance with ANSI B16.1, Class 125. Mechanical Joint Valves are in full compliance with ANSI/AWWA C111.

### Bonnet

Ductile iron domed access bonnet allows for easy removal and inspection of the flexible disc assembly.

### Disc

The only moving part, featuring a fully Buna-N encapsulated steel disc with nylon reinforcement in the flex area. The molded elastomer with integral O-ring ensures a bubble-tight shut off, without backflow.

### Body Seat

Constructed on a 45 degree angle to reduce the travel of the disc to the full open position; significantly reducing the potential for water hammer.

### Flow

The flow area is equal to or greater than the equivalent pipe size throughout, resulting in low head losses, compared to other types of check valves.

### Installation

Suitable for both horizontal and vertical pipelines with flow upward.

### Coatings & Exteriors

The valve interior is fully coated with NSF 61 approved liquid thermosetting epoxy suitable for use in potable water service.

### Accessories/Options (for flanged valves only)

- Disc position indicator (3" - 16" only)
- Disc position indicator with limit switch (3" - 16" only)
- Glass lined
- Rubber Lined
- External backflow device - to manually open disc
- Proximity limit switch - to transmit an electrical signal to indicate when disc is open or closed
- EPDM disc option
- Stainless steel cover bolts

**2" TO 24" FIGURE 851 FLANGED END FLEX CHECK VALVES 250 PSI**

VALVE SIZE	A	B	C	D	E
2	8.0	2.0	3.38	5.75	5.2
2-1/2	8.5	2.5	3.38	5.75	6.8
3	9.5	3.0	3.88	8.28	7.4
4	11.5	4.0	4.63	9.25	9.0
6	15.0	6.0	5.88	10.28	10.9
8	19.5	8.0	7.63	12.28	14.2
10	24.5	10.0	9.88	14.28	19.6
12	27.5	12.0	11.38	15.78	21.3
14	31.0	14.0	13.38	17.78	25.8
16	32.0	16.0	15.38	19.78	25.2
18	36.0	18.0	17.13	28.94	29.1
20	40.0	20.0	19.13	31.13	31.9
24	48.0	24.0	22.75	38.75	38.3

ITEM	QTY	DESCRIPTION	MATERIAL	ASTM DESIGNATION
1	1	BODY	DUCTILE IRON	ASTM A-536-GR 65-45-12
2	1	BONNET	DUCTILE IRON	ASTM A-536-GR 65-45-12
3	1	DISC	STEEL/BUNA N	ASTM A-36 / D2000 BK 807
4	1	GASKET	RUBBER (BUNA N)	D2000 BK 807
5	AR	CAP BOLTS	STEEL/ZINC	SAE GRADE 5 - ZINC PLATED
6	1	INTERIOR LINING	EPOXY	-
7	1	PLUG	DUCTILE IRON	ASTM A-536-GR 65-45-12
*8	1	BOSS COVER	DUCTILE IRON	ASTM A-536-GR 65-45-12
*9	1	O-RING	RUBBER (BUNA N)	D2000 BK 807
*10	4	BOSS COVER BOLTS	STEEL/ZINC	SAE GRADE 5 - ZINC PLATED

**NOTES:**

- 1- (\*) 3" TO 16" CHECK VALVES ONLY.
- 2- DIMENSION "D" REQUIRED TO REMOVE ACCESS COVER.
- 3- FLANGES ARE PER ANSI B16.1 CL. 125/150 FLAT FACED.

**Suggested Specifications**

Check valve shall be of the flanged, full body type with no internal moving parts except for the resilient disc. The flanged ends shall be manufactured in accordance with ANSI B16.1 Class 125. Valves shall be rated to 250 psi for all sizes.

The valve body shall be constructed of ductile iron ASTM A-536 Grade 65-45-12 with flow area equal to the nominal pipe inside diameter throughout the valve. Seat shall be constructed on a 45 degree angle to reduce disc travel. The seat and internal body shall be fully coated with a two part thermosetting epoxy suitable for use in both potable water and wastewater applications.

The domed bonnet shall be manufactured of ductile iron ASTM A-536 Grade 65-45-12. The bonnet-to-body seal shall be provided by a gasket to allow easy removal and replacement of the access bonnet. Bonnet bolting shall be SAE Grade 5 zinc plated.

The resilient disc shall feature a fully encapsulated steel pressure plate with integral molded O-ring on the face of the elastomer. Nylon reinforcements shall be provided in the flexible hinge area of the disc assembly.

If requested the manufacturer shall furnish certified results of a proof of design test performed at an independent testing laboratory. Testing shall include a million-cycle continuous test to demonstrate the durability of the flexible connection.

2" TO 2-1/2" AND 18" TO 24"

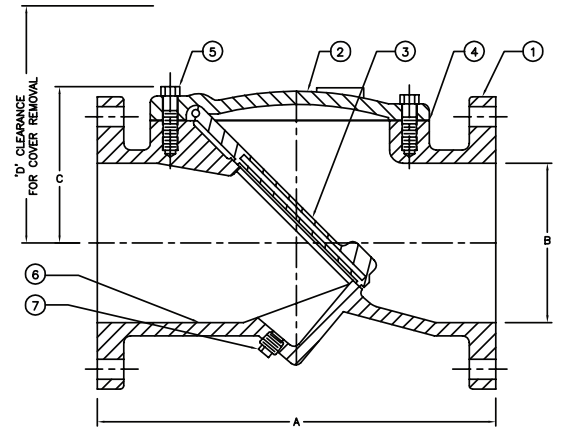

3" TO 16"

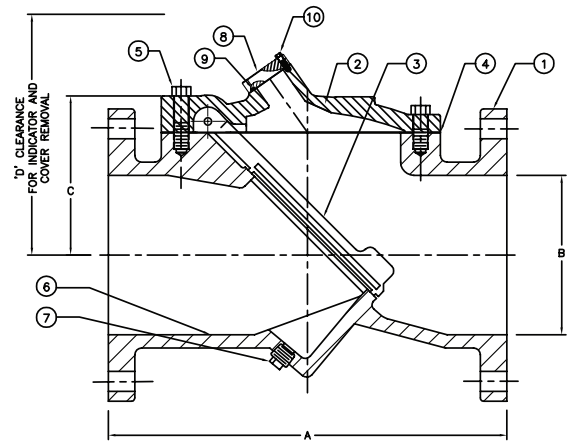

SECTION F-F

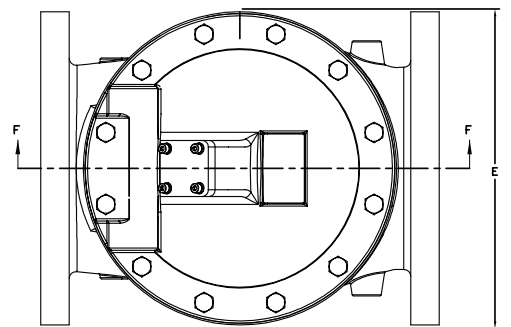

### 3" TO 16" FIGURE 850 MECHANICAL JOINT END FLEX CHECK VALVES 250 PSI

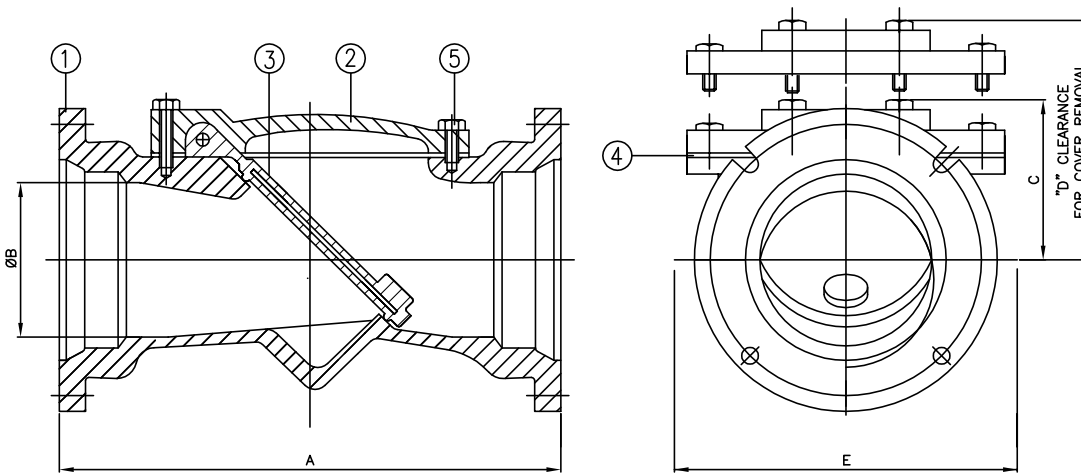

VALVE SIZE	A	B	C	D	E
3	13.00	3.0	3.90	4.69	7.75
4	14.96	4.0	4.65	5.63	9.25
6	19.30	6.0	6.22	7.28	12.00
8	23.81	8.0	7.80	8.98	15.00
10	28.34	10.0	10.20	11.54	20.00
12	33.00	12.0	11.38	12.80	22.00
14	35.00	14.0	12.00	13.89	-
16	37.00	16.0	13.58	15.16	25.25

ITEM	QTY	DESCRIPTION	MATERIAL	ASTM DESIGNATION
1	1	BODY	DUCTILE IRON	ASTM A-536-GR 65-45-12
2	1	BONNET	DUCTILE IRON	ASTM A-536-GR 65-45-12
3	1	DISC	STEEL/BUNA N	ASTM A-36 / D2000 BK 807
4	1	GASKET	RUBBER (BUNA N)	D2000 BK 807
5	AR	CAP BOLTS	STAINLESS STEEL	A 276 TYPE 304

**NOTES:**

- 1- MECHANICAL JOINT ENDS ARE PER ANSI/AWWA C111/A21.11.
- 2- DIMENSION "D" REQUIRED TO REMOVE ACCESS COVER.
- 3- SUPPLIED WITH AMERLOCK 2 RED OXIDE EPOXY.

#### Suggested Specifications

Check valve shall be of the mechanical joint, full body type with no internal moving parts except for the resilient disc. The mechanical joint ends shall be manufactured in accordance with ANSI/AWWA C111. Valves shall be rated to 250 psi for all sizes.

The valve body shall be constructed of ductile iron ASTM A-536 Grade 65-45-12 with flow area equal to the nominal pipe inside diameter throughout the valve. Seat shall be constructed on a 45 degree angle to reduce disc travel. The seat and internal body shall be fully coated with a two part thermosetting epoxy suitable for use in both potable water and wastewater applications.

The domed bonnet shall be manufactured of ductile iron ASTM A-536 Grade 65-45-12. The bonnet-to-body seal shall be provided by a gasket to allow easy removal and replacement of the access bonnet. Bonnet bolting shall be stainless steel A276 Type 304.

The resilient disc shall feature a fully encapsulated steel pressure plate with integral molded O-ring on the face of the elastomer. Nylon reinforcements shall be provided in the flexible hinge area of the disc assembly.

If requested the manufacturer shall furnish certified results of a proof of design test performed at an independent testing laboratory. Testing shall include a million-cycle continuous test to demonstrate the durability of the flexible connection.

