

June 2010

**Operation and Maintenance
Manual
Series 9001A with Air Cushion**



**Milliken Valve Company
2625 Brodhead Road, Suite 100
Bethlehem, PA 18020
Phone: (610) 861-8803
Fax: (610) 861-8094
Website: www.millikenvalve.com**

Operations & Maintenance

DESCRIPTION

CCNE CHECK VALVES

SERIES 9001 WITH AIR CUSHION

Series 9001 swing check valves are of self-contained, free-swinging disc style with outside lever and weight or outside lever and spring, with bronze air cushion. Valves conform to all standards set forth in AWWA C508. Suitable for use in wastewater, water, sewage, oil, and gas applications. Valves are produced in cast iron body, stainless steel seat rings, Buna-N or EPDM disc inserts, and hinge pins of corrosion resistant stainless steel. Internal and external epoxy coating conforming to AWWA C550 is a standard. Valves are designed for horizontal or vertical installations and for uninterrupted continuous service.

Operations & Maintenance

THEORY OF OPERATION

The Milliken/CCNE check valve is a non-return valve that allows the fluid to pass through the disc, but will not allow it to return because the disc closes and stops the flow.

This valve requires approximately $\frac{1}{2}$ psi to open. The valve can be equipped with weight on the arm or a spring.

Operations & Maintenance

PRE START-UP CHECK

All valves should be inspected at time of delivery for shipping damage and to confirm compliance with specifications. Whenever possible, the valves and all apparatus should be protected from the weather. Water and debris should not collect in the valve. Note; these instructions are guidelines for use by experienced piping and mechanical personnel.

Operations & Maintenance

SAFETY

Valves are to be handled by experienced installers. They should never be used as structural members and should be appropriately rigged for lifting. Valves are heavy and include various accessories, which should be handled with caution.

TOOLS AND EQUIPMENT NEEDED:

STANDARD BOX WRENCHES

PIN DRIVERS

BALL PEEN HAMMER

RIGGING EQUIPMENT

PACKING PULLER

PACKING CUTTER

CHAIN HOIST

Operations & Maintenance

STORAGE

Store valves closed. Store on end flange or in the horizontal position. They should be stored inside or covered away from weather. If valves must be stored outside, protect them from weather. Valves on jobsites should be protected to avoid physical damage from heavy equipment or tools.

Outside lever and spring components should be protected to avoid inadvertent contact.

Make sure valves are kept drained of water in freezing weather to prevent cracking of iron parts. All coatings shall be protected to avoid damage from handling, weather, and light rays.

Operations & Maintenance

INSTALLATION INSTRUCTIONS

A) Check that valve end joints conform to the mating pipe and verify that ends are clean and sound. All 9001 series valves are supplied with flat faced flanges with ANSI class 125 drilling. Do not mate these valves to pipe or fittings with raised face flanges.

B) Remove any material used to restrain the flow control device, lever or pin during shipment and storage. Attach any outside closing mechanism in proper position manually.

C) The flow control device and closing mechanism should be checked to insure freedom of motion and proper operation. Cover bolts shall be checked for any loose joints.

D) When handling the valve, do not use the outside mechanisms for lifting.

E) It is necessary to install the valve in proper orientation with regard to flow direction. Please note flow arrow on side of body.

F) Prepare pipe ends per pipe manufactures instruction and install valve as per appropriate instructions for the specific joint. All piping should be properly supported to avoid line stress on the valve. Do not use valves as a jack to force a pipeline in position.

G) Standard wrenches and/or sockets are to be used to tighten all nuts and bolts. Fasteners are to be tightened in a star pattern to insure balance loading of bolts.

Operations & Maintenance

MAINTENANCE INSTRUCTIONS

The system is designed to be trouble free with minimum care. Frequency of inspection should be based on the operational characteristics of the system i.e. systems of high cycles should be inspected frequently.

At a minimum, semi-annual inspections are recommended, points of inspection should be at a minimum:

- 1) All end joints, cover joints, and packing boxes should be inspected for leakage.
- 2) Bolts should be checked for tightness, a torque of 90 foot pounds is recommended for gasketed joints.
- 3) Inspection of the valve during operations is recommended so that the outside linkages can be inspected for proper operation.
- 4) Inspection of the packing box is required to assure no leakage is evident. If leakage exists, replace o rings (part 351). Do not tighten end plug to stop leak. Caution: o rings should not be changed or added in an active valve. Valve should be isolated to prevent injury or damage to valve and operator.
- 5) Inspection of interior of valve is not necessary unless improper operation is witnessed or leakage beyond the allowable rate is experienced. The interior of the valve and the internal components can be inspected by removing the valve cover. Cover gasket should be replaced any time this joint is broken. Never re-installed a used cover gasket.
- 6) Care should be taken to keep rod of cylinder free from dirt or other materials. Breather filters should be periodically cleaned.

Operations & Maintenance

OPERATING INSTRUCTIONS

Once in the pipeline, the swing check valve will operate as flow conditions dictate. The valve will open as the pressure on the upstream side of the disc overcomes the downstream side. The valve will close as the situation reverses itself or the pressure equalizes.

The adjustment of weight and/or the addition of springs to assist closure may be necessary.

These valves are self contained units. Outside levers, weights, springs, or hinge pins should never be used to manually operate the valve or restrict its operation.

External shields and surrounding piping should not interfere with the free operation of external apparatus of the valves.

Operations & Maintenance

ASSEMBLY/DISASSEMBLY FOR **AIR CUSHIONS**

Good housekeeping practices should be used to prevent any debris and foreign matter from interfering with the operation of the cylinder and possibly causing damage to the internal or external cylinder components.

At a minimum, the air cylinder should be inspected semi-annually for the following:

- 1) External damage to the tube and linkage connections. Any damage should be reported for instructions or replacement of the appropriate components.
- 2) Inspect piston rod for signs of wear, nicks, dents, scratches, or anything that may damage the seals. Piston rod should be clean of any foreign matter or debris. In the event that the piston rod is found to be damaged, please contact us for replacement information.
- 3) If cylinder is found to have leakage by the piston rod, contact us for instructions.

Operations & Maintenance

AIR CUSHION MAINTENANCE ADJUSTMENT

Make sure air regulator **A** is opened completely (never close this regulator completely). If valve closes too hard, then adjust accordingly. Further adjustment can be made by loosening the bolt(s) **B** and adjusting the weight along the lever arm.

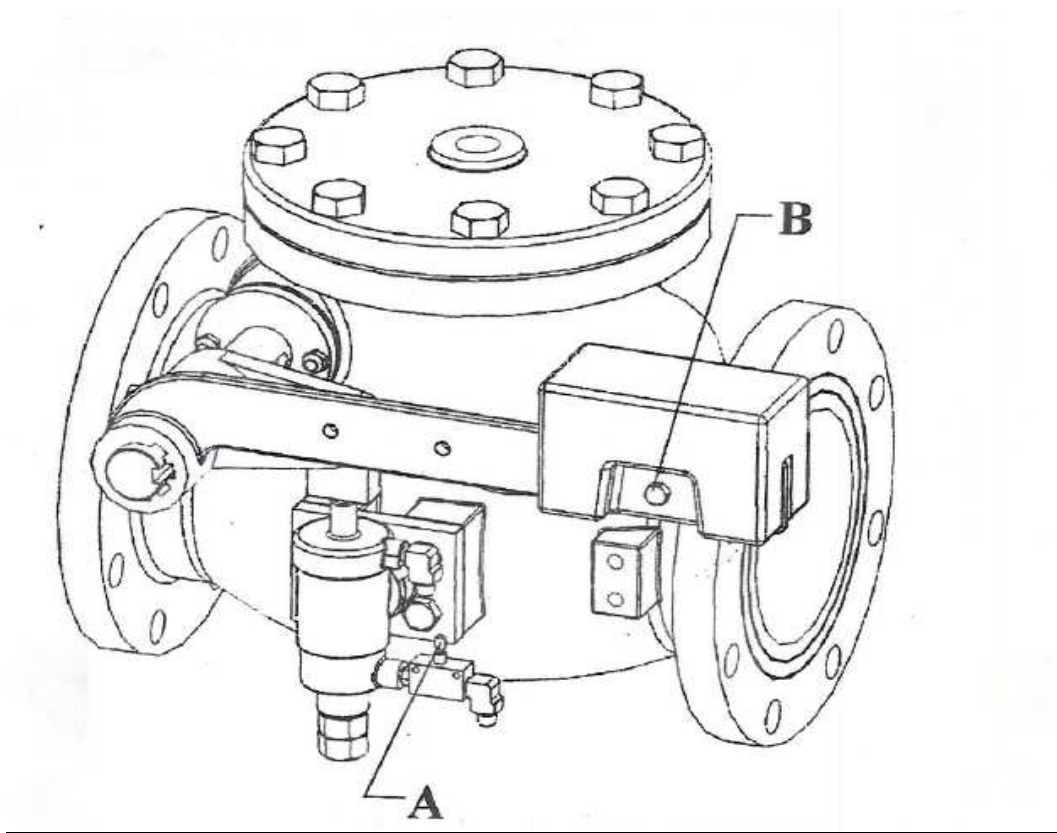

Operations & Maintenance

AIR CUSHION MAINTENANCE PROCEDURE

The following procedure should be performed quarterly using a lightweight lubricant such as WD-40.

- 1) Lubricated the pin to teardrop connection.
- 2) Inspect piston rod shaft. Make sure it is clean of debris. Inspect the seal on top of piston to see if it is in good shape. Lubricate piston shaft.
- 3) Lubricated pivot point of air cushion.
- 4) Make sure lower and upper breathers are clear of debris.

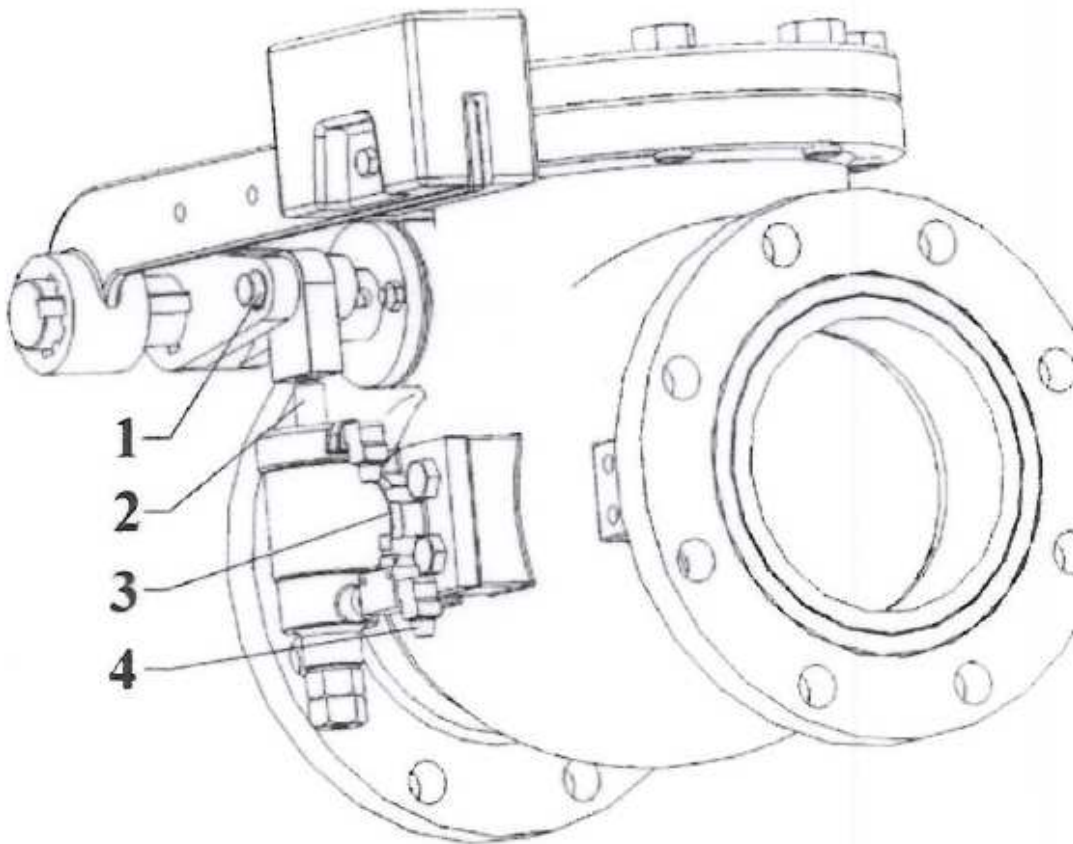

Operations & Maintenance

TROUBLESHOOTING

POSSIBLE MALFUNCTION	SYMPTOMS/ CAUSE	CORRECTIVE ACTION
End Joint Leakage	Tension on bolts relaxed	Tighten bolts in Star pattern
Cover Gasket Leakage	Relaxed Cover bolts tension	Tighten Bolts in Star Pattern. Should leakage Continue, replace Gasket
Valve Slams While Closing	Weight needs adjustment	Adjust weight location/ Addition of spring kit req'd
Seat Leakage	Seats Dirty	Remove inspection Cover and flush
	Disc Seat Damaged	Replace Buna-N Insert or Replace Disc
Leak by Hinge Pin	Cracked or Broken O Rings	Replace O Rings

Operations & Maintenance

LUBRICATION

Under normal operation, lubrication is not required to maintain proper operation of components or assembled units.

Operations & Maintenance

SERIES 9001 RECOMMENDED SPARE PARTS

RECOMMENDED SPARE PARTS:

<u>PART</u>	<u>MATERIAL</u>	<u>QTY PER VALVE</u>	<u>PART #</u>
COVER GASKET	BUNA-N	1	90-324
O RING KIT*	BUNA-N	1	90-351/352-KIT
AIR CUSHION	BRONZE	1	BC

*Includes (2) internal and (2) external O rings