



**MILLIKEN  
GENERAL SERVICE  
BUTTERFLY VALVE  
OPERATION & MAINTENANCE  
MANUAL**

**SERIES 565/566**

Milliken Valve Company  
2625 Brodhead Avenue, Suite 100  
Bethlehem, PA 18020  
Phone: (610) 861-8803  
Fax: (610) 861-8094  
Website: [www.millikenvalve.com](http://www.millikenvalve.com)

## OPERATION & MAINTENANCE

### INSTALLATION

Prior to installation, the butterfly valves and the mating flanges should be inspected to assure gasket surfaces are free of defects. Because the elastomer seat of the valve acts as an integral gasket flange gaskets are not required. Valves should not be installed between flanges with damaged surfaces. Piping should also be checked for proper alignment. Lugged butterfly valves should never be used to align improperly positioned pipe. The distance between pipe flanges should be checked to assure proper clearance of valve installation. The valve should be in the partially closed position when being placed between flanges. For wafer valves the valve must be visually centered with respect to the flange faces while lugged valves may be centered using the flange bolting. The valve should be cycled to assure not binding or interference is taking place.

Flange bolting should be tightened gradually in a star or crisscross pattern according to the following sequence.

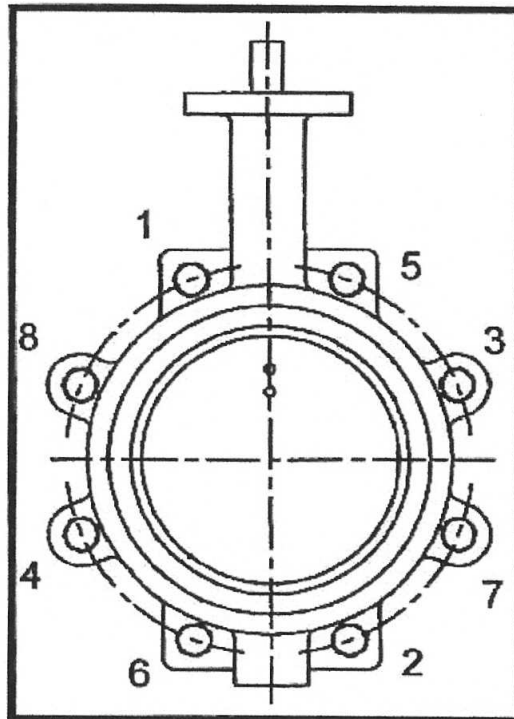

The flange joint is complete after the valve body is against the flange faces with no gaps present. Bolting should then be tightened sufficiently to prevent loosening of the joint.

## OPERATION & MAINTENANCE

### MAINTENANCE INSTRUCTIONS

The Milliken General Service Butterfly Valve is designed and manufactured to be a long life valve under normal circumstances. It does not require any routine maintenance or lubrication. It is recommended that the following practices be followed on at least a monthly basis:

1. Cycle the valve from full open to close to assure operability.
2. Check fasteners for evidence of loosening.
3. Inspect valve and surrounding area for previous or existing leakage at the flange face or stem area.
4. Check pipe or wiring to actuator for loosening, corrosion or defects and make corrections as required.

However, if maintenance is required, due to unusual wear or service conditions the following procedure should be followed:

### REMOVAL FROM PIPELINE

Prior to loosening the flange bolts (with valve in open position):

1. Drain piping run as much as possible.
2. Vent line to relieve any pressure.

Close valve, then:

1. Disconnect air or electric lines (if applicable) and tag for reinstallation.
2. Loosen flange bolts to decompress valve gasket seals.
3. Secure necessary lifting equipment to valve assembly.
4. Remove flange bolting from between pipe flanges.